

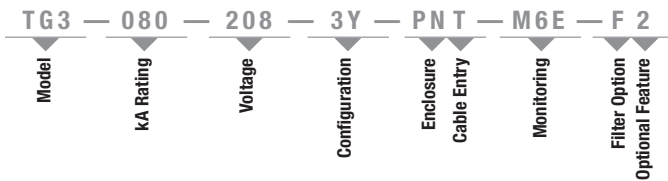

MODEL NUMBER SCHEME (TG3SM)

E.g.: TG3-080-208-3Y-PNT-M6E-F2 (as shown in above photo)



kA Rating (Must Choose One)

Available TG3SM kA Ratings:
050, 080, 100, 125, 150, 200,
250, 300

Voltage* (Must Choose One)

208	120/208
240	120/240
380	220/380
480	277/480
600	347/600

Configuration* (Must Choose One)

1G	1-Phase, Grounded
2G	2-Phase, Grounded, Split-Phase
3Y	3-Phase, Grounded, Wye
3R	3-Phase, Grounded, High-Resistance
3H	3-Phase, Grounded, High-Leg Delta
3D	3-Phase, Grounded, Delta

Enclosure (Must Choose One)

MN	Metal Without Disconnect
MD	Metal With Disconnect
SN	Stainless Steel Without Disconnect
SD	Stainless Steel With Disconnect
PN	Fiberglass Reinforced Polyester Without Disconnect

Cable Entry (Must Choose One)

T	Top Feed
B	Bottom Feed

Monitoring (Must Choose One)

M0	No local monitoring (see remote MxX stand-alone option)
M1	LED/Phase + Audible Alarm, Dry Relay Contacts
M2	M1 + Surge Counter
M3	Advanced Monitoring, Character Display, Modbus RTU
M4E	M3 + Ethernet, Modbus TCP
M5	Advanced Monitoring, Graphics Display, Modbus RTU
M6E	M5 + Ethernet, Modbus TCP

Filter (Must Choose One)

F	Filter
N	No Filter

Optional Feature (May Choose One)

2	Test Port
---	-----------

Stand-Alone Options

(To Be Ordered As Separate Items)

DTS	DTS-2 Diagnostic Test Set
MxX	Remote Monitor Extension M1X through M6EX
HPI	HPI Cable

TransGuard[®] TG3SM suppression filter systems feature a powerful failure-free ISM[™] (Integrated Suppression Module). The ISM[™] contains individual thermally fused and protected MOVs, surge-rated copper busing, robust filtering and advanced remote communications capabilities. The TG3SM protects today's facilities from costly downtime and equipment damage caused by routine or catastrophic electrical disturbances.

PRODUCT SPECIFICATIONS

General Specifications

Maximum Surge Current Rating	80kA Per Mode, 160kA Per Phase
Nominal Discharge Surge Current	I-n = 20kA
Safety Listings	UL Listed 1449 4th Edition for Type 1 and Type 2 SPD applications, cUL, and UL 1283 / Meets Requirements for UL 96A / Compliant to IEEE C62.41.1-2002, C62.41.2-2002 and C62.45-2002 / NFPA 70 [NEC], Article 285 / RoHS Compliant / CE, IEC 61643-11-2011 / FCC Part B Class B / EMC Directive 2004/108/EC / Low Voltage Directive 2006/95/EC
Protection Method	Thermally protected MOVs, Capacitive Filter
Product Design	Individual thermally fused and protected MOVs, and All Copper, Tin-plated Bus
Dimensions	Metal/Stainless Steel: 16"H x 16"W x 9.2"D Fiberglass Reinforced Polyester: 14"H x 12.75"W x 6.6"D
Weight.	Metal/Stainless Steel: 40 lbs. Fiberglass Reinforced Polyester: 17 lbs
Enclosure Type	NEMA 4/12 Standard (NEMA 4X Option)
Installation Location	Outdoor or Indoor
Operating Environment	-25°C to +60°C 5% – 95% Non-Condensing Humidity
Fault Current (SCCR)	200kAIC
Connection Method	Parallel
Protection Modes	All Modes (L-N, L-G, N-G, L-L)
Response Time	< 0.5 Nanoseconds
Operating Frequency	47 – 63 Hz
Warranty	15 Years

Filtering Attenuation Frequencies (Per Mil-Std-220B January 2000)**

10 KHz	100 KHz	1 MHz	10 MHz	Max at 142 KHz
18.1 dB	44 dB	22.8 dB	15.3 dB	54.6 dB

Single/Repetitive Surge Current Capacities (Tested)**

Protection Mode	Single Pulse Surge Current Capacity/Mode	Repetitive Surge Current Capacity/Mode
Line-to-Neutral	80,000A	6,000 Impulses
Line-to-Ground	80,000A	6,000 Impulses
Neutral-to-Ground	80,000A	6,000 Impulses
Line-to-Line	160,000A	12,000 Impulses
Per Phase	160,000A	12,000 Impulses

Maximum Continuous Operating Voltage (MCOV)

Voltage	L-N MCOV	Voltage	L-L MCOV
120V	150V	240V	300V
277V	320V	480V	552V
347V	420V	600V	690V

** Data based on actual tests. Contact factory for test reports



*See table on back for more Voltage/Configuration Options.



DIMENSIONAL SPECIFICATIONS

Metal/Stainless Steel

TG3™/80	Inches	(mm)
H1	16.00	(406.4)
H2	17.25	(438.2)
H3	18.50	(469.9)
W1	16.00	(406.4)
W2	10.00	(254.0)
D	9.20	(233.7)

Fiberglass Reinforced Polyester

TG3™/80	Inches	(mm)
H1	14.00	(355.6)
H2	14.75	(374.7)
H3	15.50	(393.7)
W1	12.75	(323.9)
W2	10.00	(254.0)
D	6.60	(167.6)

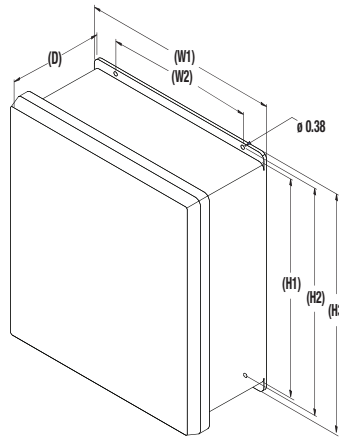
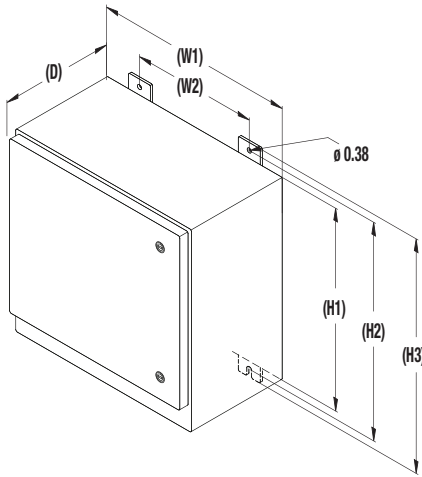

VOLTAGE/CONFIGURATION OPTIONS

Not all voltage configurations are displayed, contact Thomas & Betts Power Solutions for additional configurations.

Voltage	Configuration					
	1G	2G	3Y	3R	3H	3D
120	X					
208	X		X	X		X
220	X	X		X		X
230	X					X
240	X	X			X	X
380		X	X	X		X
415		X	X	X		X
480		X	X	X		X
600		X	X	X		X

TG3™/80 PERFORMANCE DATA

System Voltage	120/240V or 120/208V				277/480V				347/600V				480V Delta	
	L-N	L-G	N-G	L-L	L-N	L-G	N-G	L-L	L-N	L-G	N-G	L-L	L-G	L-L
Protection Mode	L-N	L-G	N-G	L-L	L-N	L-G	N-G	L-L	L-N	L-G	N-G	L-L	L-G	L-L
MCOV	150	150	150	300	320	320	320	552	420	420	420	690	552	552
B3 Ring Wave 6kV, 500A	490	570	640	500	450	540	570	530	490	520	600	550	1450	530
B3/C1 Combo Wave 6kV, 3kA	614	629	634	1011	1013	1031	950	1857	1197	1219	1175	2369	1542	1857
C3 Combo Wave 20kV, 10kA	980	980	1170	1600	1420	1540	1600	2600	1670	1670	1730	2980	2270	2600
UL 1449 4th Edition VPR 6kV, 3kA	700	700	700	1200	1200	1200	1000	2000	1200	1500	1200	2500	1800	2000

All TG3™ systems voltage protection ratings (VPR) are peak values (±10%) measured from the 90° reference point and are in compliance with test and evaluation procedures outlined in ANSI/IEEE C62.41





Ingeniería, Protección y Potencia de México

General Miguel Barragán #814
Aguascaliente, Ags.
01 (449) 145 2028
ippm.mx